

Generator and Control Box

TESTS



F O R E W O R D

This booklet is intended primarily for the small service station owner and mechanic who, though not normally concerned with car “ electrics,” are nevertheless required at some time or other to diagnose and correct electrical faults.

We believe that this booklet will serve to show you a way in which some of the more common faults in the generator and regulator, on Lucas equipped cars and motor cycles, can be diagnosed and corrected—in many cases without having to remove the units from the vehicle. Quick diagnosis is ensured if the tests are carried out in the systematic manner outlined herein.

Remember, always commence the tests at the source of supply—The Generator (Part 1, Test 1).

INDEX OF SYSTEMATIC FAULT LOCATION PROCEDURE

PART 1	PART 2	PART 3	PART 4
Generator Tests for Models: C39PV C42 C39Q C45PV-5 C40A C45PV-6 C40/1 C45PVS-6 C40AL C47 C40L C48 C40LQ Pages 3 – 4	Regulator Tests: Compensated Voltage Control. Lucas Models: MCR1, MCR2, RF95, RF95/3, RF96, RF97, RB106/1, RB106/2, RB107 and RB108 Pages 5 – 9	Regulator Tests: Current Voltage Control. Lucas Model: RB310 3 Bobbin Type with screw type electrical adjustment Pages 10 – 16	Regulator Tests: Current Voltage Control. Lucas Model: RB340 3 Bobbin Type with cam type electrical adjustment Pages 17 – 26

©Printed in England

No part of this book may be reproduced without permission.

The following tests should be carried out with a good quality Moving Coil Voltmeter. The meter should have a full scale deflection of at least 20 volts, with divisions suitable for taking readings to within 0.5 of a volt. A meter of this standard will be suitable for both 6 and 12-volt LUCAS equipped cars, trucks, etc., and 6 volt systems on motor cycles.

ALWAYS CHECK BATTERY CONDITION BEFORE COMMENCING TESTS

PART 1

GENERATOR TESTS WITH THE MACHINE IN POSITION ON THE VEHICLE

Inspect generator mounting for tightness of bolts, etc.

Inspect the fan belt for correct tension, adjust if necessary. If worn or frayed fit a new belt. Make sure drive pulleys are correctly aligned.

If the belt and generator mounting are satisfactory and pulleys correctly aligned then proceed to Test 1.

VOLTMETER CONNECTION	READING	ACTION
TEST 1. Disconnect leads from generator. Connect one lead of voltmeter to D terminal and the other to a good ground. Start engine and raise speed until generator is running at approx. 3,000 rev/min. When vehicle has a positive ground system positive meter lead must be grounded.	A. 2-4 volts as generator is run up to charging speed (approx. 3,000 rev/min) (6 and 12 volt systems).	Armature and brush connections O.K. proceed to Test 2.
	B. Zero volts.	Examine brushes and make sure they are free in their boxes making good contact on the commutator. If still no reading fault is in armature, which has to be replaced.
	C. Rising volts with rising speed.	Internal short between D and F terminals, examine field coils and rectify as necessary or fit replacement.

VOLTMETER CONNECTION	READING	ACTION
<p>TEST 2. Connect meter as in Test 1. Link terminals D and F on generator. Gradually speed up engine to fast "tick-over" speed. If an ammeter is used to link D and F, reading should not be more than* 2 amps, when normal voltage of system is registered on voltmeter. *2.5 for C42 with 4½ ohm field.</p>	<p>A. Rising volts with rising speed—full scale reading at fast tick-over.</p>	<p>Generator in order, proceed to Test 3.</p>
	<p>B. 2-4 volts as engine is revved up (6 and 12 volt systems).</p>	<p>Open circuit in field coils, rectify as necessary or fit replacement.</p>
	<p>C. Zero volts.</p>	<p>Grounded field coils or field connection, rectify as necessary or fit replacement.</p>
<p>TEST 3. Reconnect leads of generator. Remove leads from D and F terminals at the control box. Connect one side of voltmeter to end of D lead, the other to a good ground, speed generator up to approx. 3,000 rev/min.</p>	<p>A. 2-4 volts (6 and 12 volt systems).</p>	<p>D lead from generator to control box is in order. Proceed to Test 4.</p>
	<p>B. Zero volts.</p>	<p>Rewire D lead which is open-circuited, or earthed.</p>
	<p>C. Rising volts with rising speed.</p>	<p>Locate short between D and F cables.</p>
<p>TEST 4. Leave voltmeter connected as in Test 3. Join D and F wires together. Gradually speed up engine to fast "tick-over" speed.</p>	<p>A. Rising volts with rising speed.</p>	<p>Cables from generator to control box are in order. Proceed to Test 5 in part 2, 3, or 4 whichever is applicable.</p>
	<p>B. Zero volts.</p>	<p>Earthed F lead.</p>
	<p>C. 2-4 volts (6 and 12 volt systems).</p>	<p>Open circuit in field lead between generator and control box.</p>

PART 2

MODEL LRT9 REGULATOR — SINGLE CONTACT 2 BOBBIN TYPE (Used with RF95, 96, RB106/1, MCR2, etc.)

COMPENSATED VOLTAGE CONTROL TESTS WITH UNIT IN POSITION

On no account must these tests be made with the battery in circuit.

To isolate the battery from the generator put a piece of dry card between the cut-out points. Remember the output of the generator, that is the current in amps. flowing from the generator to the battery is dependent on the state of charge of the battery. The generator will give a high output when the battery is in a low state of charge and a low output when the battery is fully charged. Regulators must therefore always be set on open-circuit, a condition which is most easily obtained by inserting the piece of dry card as described above, alternatively, withdraw cables from 'A' and A1 terminals and join together temporarily.

VOLTMETER CONNECTION	READING	ACTION
TEST 5. Reconnect generator leads to control box terminals D and F. Connect one lead of voltmeter to terminal A, the other to terminal E on the control box. Engine stationary.	A. Battery voltage.	Regulator ground connection in good order. Proceed to Test 6.
	B. Less than battery voltage, or zero reading.	Rectify bad ground or broken ground wire between terminal E and chassis.

VOLTMETER CONNECTION	READING	ACTION											
<p>TEST 6. Proceed to check regulator setting. Remove control box cover. Isolate the battery by placing a piece of dry card between cut-out contacts, alternatively, remove 'A' and A1 cables from terminals and join together temporarily. Connect one lead of voltmeter to terminal D (or frame of regulator) and the other lead to a good ground.</p>	<p>A. With generator running at approx. 3,000 rev/min voltage should remain constant within the following limits :</p> <table border="0" data-bbox="641 264 1071 398"> <thead> <tr> <th>Ambient Temp.</th> <th>6 volt Equip.</th> <th>12 volt Equip.</th> </tr> </thead> <tbody> <tr> <td>10°C 50°F</td> <td rowspan="2">8.0-8.5</td> <td rowspan="2">16.0-16.5</td> </tr> <tr> <td>20°C 68°F</td> </tr> <tr> <td>30°C 86°F</td> <td rowspan="2">8.0</td> <td rowspan="2">15.5-16.0</td> </tr> <tr> <td>40°C 104°F</td> </tr> </tbody> </table>	Ambient Temp.	6 volt Equip.	12 volt Equip.	10°C 50°F	8.0-8.5	16.0-16.5	20°C 68°F	30°C 86°F	8.0	15.5-16.0	40°C 104°F	<p>Regulator in order. Proceed to Test 7.</p>
Ambient Temp.	6 volt Equip.	12 volt Equip.											
10°C 50°F	8.0-8.5	16.0-16.5											
20°C 68°F													
30°C 86°F	8.0	15.5-16.0											
40°C 104°F													
	<p>B. Voltage remains constant, but outside the given limits.</p>	<p>Adjust regulator by turning the adjusting screw clockwise to increase or counter-clockwise to lower the setting. Check setting by raising speed from zero.</p>											
	<p>C. Rising volts with rising engine speed up to 3,000 rev/min and beyond.</p>	<p>Check 'D' and 'F' leads for short-circuit, if O.K. suspect broken shunt winding in regulator bobbin. The ground lead from control box terminal E is common to both shunt windings (regulator and cut-out). Hold a screwdriver near top of the bobbins and test for magnetic pull. If there is pull on the one bobbin core and not on the other suspect open circuit on the latter. If no pull on either check for open circuited ground lead. Replace defective regulator.</p>											

VOLTMETER CONNECTION

READING

ACTION

TEST 6 (continued).

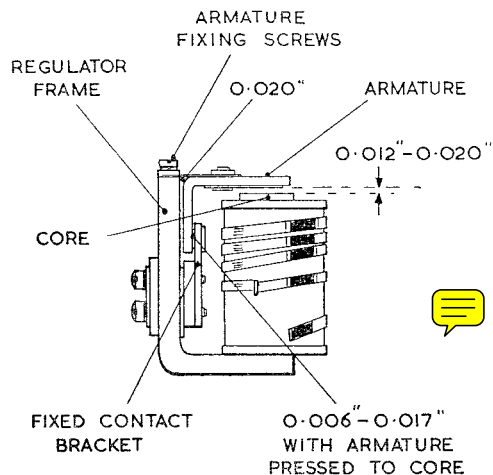

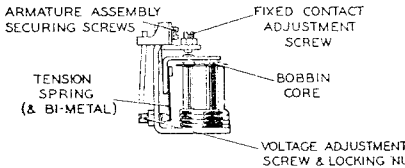



Diagram 1.

D. Reading approx. half setting.

Suspect regulator contacts not passing current causing the contacts resistor to be in circuit the whole time. To test, bridge the contacts with screw-driver. This closes the circuit between D and F and we should get rising volts with rising speed, thus proving the contacts are burnt or corroded.

E. Voltage does not rise with engine speed, or is erratic.

Check air-gap Settings Types MCR1, MCR2, RF95, 96, 97, RB106/1. Insert a 0.020" feeler gauge between the crank of the armature and the L-shaped frame, and 0.012-0.020" gauge between the top of the core and the underside of the brass shim on the armature. Loosen the screws holding the regulator armature to the top of the L-shaped frame. Press downwards and backwards. Tighten the screws and check that clearances are as shown in diagram 1.

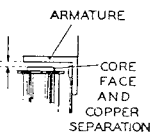
VOLTMETER CONNECTION	READING	ACTION
	<p style="text-align: center;"><u>ALTERNATIVE COPPER SEPARATION ON BOBBIN CORE</u></p> <div style="display: flex; justify-content: center; gap: 20px;">    </div> <p style="text-align: center;">DISC TWO WIRES SQUARE</p> <div style="display: flex; justify-content: space-around; align-items: center;"> <div style="text-align: center;"> <p><u>TYPE OF SEPARATION</u></p> <p>DISC OR TWO WIRES --- 0.015"</p> <p>SQUARE --- 0.021"</p> </div> <div style="text-align: center;"> <p><u>GAUGE SIZE</u></p> </div> <div style="text-align: center;">  <p>ARMATURE</p> <p>CORE FACE AND COPPER SEPARATION</p> </div> </div>	<p>Types RF95/3, RB106/2, RB107 and RB108.</p> <p>Slacken the fixed contact screw and unlock armature securing screws. Insert appropriate feeler gauge between armature and core face. Press armature down squarely against the gauge and re-tighten securing screws. With gauge in position, screw the fixed contact down until it just touches the moving contact and tighten lock nut, see diagram 2. Reset the voltage adjusting screw as described under 6B.</p>
<p style="text-align: center;">Diagram 2.</p>		
<p>TEST 7. Remove card from between cut-out contacts. Connect voltmeter to terminal A on control box and a good ground. Engine stationary.</p>	<p>Battery voltage.</p>	<p>Proving that circuit from battery through ammeter to A terminal is O.K. Proceed to Test 8.</p>
<p>TEST 8. Leaving voltmeter connected as for Test 7. Start engine and watch voltmeter.</p>	<p>A. As cut-out closes the reading should increase 0.5 to 1 volt above battery voltage, and increase to the regulator setting in Test 6.</p> <p>B. No voltage or very low voltage is recorded when cut-out points close.</p>	<p>Cut-out is in order. Proceed to Test 9.</p> <p>Clean and adjust cut-out contacts so that they meet correctly.</p>

VOLTMETER CONNECTION	READING	ACTION
TEST 9. Connect one lead of voltmeter to D terminal of regulator or to the regulator frame itself. Other voltmeter lead to a good ground.	A. Cut-out points close when voltage is within the following limits : <div style="display: flex; justify-content: space-around;"> 6 volt 6·3-6·7 12 volt 12·7-13·3 </div>	Cut-out is in good order.
	B. Cut-out points close outside above limits.	Adjust by turning adjusting screw in to increase or out to decrease the setting. Re-test with voltage rising from zero.
	C. Cut-out does not close.	Fit replacement unit.

THE FUNCTION OF THE FUSES IN THE AUXILIARY CIRCUITS IN 12 VOLT SYSTEMS

Two fuses are incorporated in RF95 control boxes. The main feed is via the ammeter to the A terminal of the control box, then through the series winding in the box to A1 terminal. Terminal A1 is also the feed to the ignition switch and from there to A3 via internal connections in the control box through the fuse to A4 terminal. Any accessories connected to A2 will work irrespective of the ignition switch position. Accessories connected to A4 will operate only when the ignition is switched on.

The system is similar on RF96, RB106 and RB106/2 control boxes, but the fuses are mounted on a separate base.

PART 3

MODEL RB310 REGULATOR — SINGLE CONTACT 3 BOBBIN TYPE CURRENT VOLTAGE CONTROL REGULATOR TESTS WITH UNIT IN POSITION

Instruments required : Moving coil Ammeter 0–40 amperes.
Moving coil Voltmeter 0–20 volts.

The Current Regulator is adjusted, before leaving the factory, to suit the rated output of the generator which it is to control. It is important therefore, that the Model of the generator is carefully noted before commencing the tests. This is stamped on the yoke of the generator.

Temperature Correction Factor

Corrections to be made to the open-circuit voltage limits when checking or adjusting settings at temperatures other than 20°C (68°F) are as follows:—

For every 10°C (18°F) *above* 20°C., *subtract*
0.1 volt from the 6-volt limits
0.2 volt from the 12-volt limits

Conversely, the same corrections must be added for every 10°C *below* 20°C.

For generator tests, repeat Tests 1 – 4, of Part 1, then proceed to Test 5, on page 11.

AMMETER CONNECTION

READING

ACTION

TEST 5 (continued).

CURRENT REGULATOR

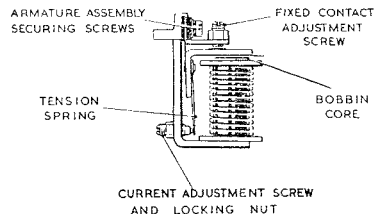

ALTERNATIVE COPPER SEPARATION ON BOBBIN CORE



TYPE OF SEPARATION
DISC
SQUARE

GAUGE SIZE
0.015"
0.018"

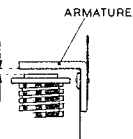

Diagram 3.

C. Current erratic or cannot be adjusted within limits.

Check air-gap setting (see diagram 3), unlock and screw back fixed contact and current adjustment screws. Slacken off armature assembly securing screws. Insert appropriate gauge between armature and copper disc on top of coil. Press armature down squarely against gauge and re-tighten securing screws.
Re-adjust current as in B and if still not within limits, fit a replacement unit.

VOLTMETER CONNECTION	READING	ACTION																					
<p>TEST 6 : Voltage Regulator.</p> <p>Remove test ammeter and leave the B (Battery) lead disconnected. Also remove clip across contact plate.</p> <p>Connect voltmeter between D terminal and ground.</p> <p>VOLTAGE REGULATOR</p>  <p>ARMATURE ASSEMBLY (REAR VIEW)</p> <p>ALTERNATIVE COPPER SEPARATION ON BOBBIN CORE</p> <p>DISC (C) SQUARE (D)</p> <p>B1 - METAL BRIGHT UNPLATED (A) OR COPPER PLATED (B)</p> <table border="1" data-bbox="94 766 389 870"> <thead> <tr> <th>TYPE OF B1-METAL AND SEPARATION</th> <th>GAUGE SIZE</th> </tr> </thead> <tbody> <tr> <td>A+C</td> <td>0.015"</td> </tr> <tr> <td>B+C</td> <td>0.015"</td> </tr> <tr> <td>A+D</td> <td>0.018"</td> </tr> <tr> <td>B+D</td> <td>0.021"</td> </tr> </tbody> </table> <p>ARMATURE</p>	TYPE OF B1-METAL AND SEPARATION	GAUGE SIZE	A+C	0.015"	B+C	0.015"	A+D	0.018"	B+D	0.021"	<p>A. Voltage rises steadily with generator running at about* 3,000 rev/min. Voltage should remain steady within the following limits:</p> <table border="1" data-bbox="617 331 1055 466"> <thead> <tr> <th>Ambient Temp.</th> <th>6 volt C/Box</th> <th>12 volt C/Box</th> </tr> </thead> <tbody> <tr> <td>10°C 50°F</td> <td rowspan="2">8.0-8.5</td> <td rowspan="2">15.0-15.5</td> </tr> <tr> <td>20°C 68°F</td> </tr> <tr> <td>30°C 86°F</td> <td rowspan="2">7.5-8.0</td> <td rowspan="2">14.5-15.0</td> </tr> <tr> <td>40°C 104°F</td> </tr> </tbody> </table> <p>With increased speed, voltage does not increase more than 1-1½ volts. *1,500 rev/min for C47 and C48.</p>	Ambient Temp.	6 volt C/Box	12 volt C/Box	10°C 50°F	8.0-8.5	15.0-15.5	20°C 68°F	30°C 86°F	7.5-8.0	14.5-15.0	40°C 104°F	<p>Regulator in order.</p> <p>Proceed to Test 7.</p>
TYPE OF B1-METAL AND SEPARATION	GAUGE SIZE																						
A+C	0.015"																						
B+C	0.015"																						
A+D	0.018"																						
B+D	0.021"																						
Ambient Temp.	6 volt C/Box	12 volt C/Box																					
10°C 50°F	8.0-8.5	15.0-15.5																					
20°C 68°F																							
30°C 86°F	7.5-8.0	14.5-15.0																					
40°C 104°F																							
	<p>B. Voltage remains constant but outside the given limits.</p>	<p>Adjust regulator by turning the adjusting screw clockwise to increase and anti-clockwise to decrease the setting.</p>																					
	<p>C. Voltage does not rise with engine speed or is erratic.</p>	<p>Check air-gap and adjust in similar manner to Test 5 (C) (see diagram 4). Re-adjust voltage as in B above and if still not within limits, fit replacement unit.</p>																					

Diagram 4.

VOLTMETER CONNECTION	READING	ACTION
<p>TEST 6 (continued).</p>  <p>The diagram shows a cross-section of a voltage regulator bobbin assembly. It features a central bobbin core with multiple layers of shunt windings. A fixed contact adjustment screw is positioned at the top, and an armature assembly is secured with screws. A tension spring is attached to the bottom of the assembly. A voltage adjustment screw and locking nut are located at the bottom left.</p>	<p>D. Rising volts with rising engine, speed up to 3,000 rev/min and beyond.</p>	<p>Check 'D' and 'F' leads for short-circuit, if O.K. suspect broken shunt winding in regulator bobbin. Shunt windings on both voltage regulator and cut-out bobbins are to common earth. Hold a screwdriver near top of voltage and cut-out bobbins and test for magnetic pull.</p> <p>If no pull check for open circuited ground lead or shunt winding.</p> <p>If defective fit replacement regulator.</p>
<p>TEST 7.</p> <p>Re-connect B lead to regulator. Connect voltmeter to B terminal and to a good ground. Engine stationary.</p>	<p>Battery Voltage.</p>	<p>Circuit from battery to regulator in order.</p> <p>Proceed to Test 8.</p>

VOLTMETER CONNECTION	READING	ACTION				
<p>TEST 8.</p> <p>Leaving voltmeter connected as for Test 7, start engine and slowly increase speed and watch voltmeter.</p>	<p>A. As cut-out closes, reading increases to 0.5 to 1.0 volts above battery voltage and increases as speed is increased to the regulator setting voltage in Test 6.</p>	<p>Cut-out is in order. Proceed to Test 9.</p>				
	<p>B. No voltage or very low voltage is recorded when cut-out points close.</p>	<p>Clean and adjust cut-out contacts so that they meet correctly. With 0.010" gauge between armature and bobbin core face contacts should be just touching.</p>				
<p>TEST 9.</p> <p>Connect one lead of voltmeter to D terminal of regulator and other voltmeter lead to a good ground.</p>	<p>A. Cut-out points close when voltage is within the following limits :</p> <table data-bbox="646 677 1029 736"> <tr> <td style="text-align: center;">6 volt</td> <td style="text-align: center;">12 volt</td> </tr> <tr> <td style="text-align: center;">6.3-6.7</td> <td style="text-align: center;">12.7-13.3</td> </tr> </table>	6 volt	12 volt	6.3-6.7	12.7-13.3	<p>Cut-out in good order and correctly set Proceed to FINAL CHECK.</p>
	6 volt	12 volt				
	6.3-6.7	12.7-13.3				
<p>B. Cut-out points close outside above limits.</p>	<p>Adjust by turning adjustment screw in to increase or out to decrease setting.</p>					
<p>C. Cut-out does not close.</p>	<p>Fit replacement unit.</p>					

AMMETER CONNECTION	READING	ACTION
<p>TEST 10. FINAL CHECK.</p> <p>Leave voltmeter connected as for Test 9.</p> <p>Insert ammeter again between terminal B and A cable as in Test 5.</p> <p>Steadily increase engine speed and watch both meters.</p> <p>Switch on full lighting load.</p>	<p>As speed increases cut-out closes between 12.7-13.3 volts and charging rate builds up with increasing speed.</p> <p>Ammeter reading equals maximum rated output of the generator.</p>	

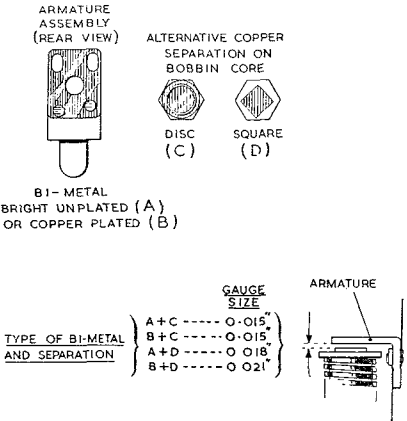
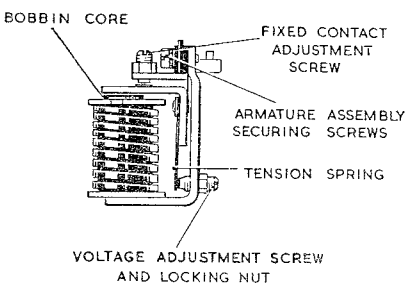
METRIC EQUIVALENTS

$\frac{3}{32}$ " dia. = 2.38 mm.

$\frac{5}{64}$ " dia. = 1.98 mm.

0.005" = 0.127 mm.

0.006" = 0.152 mm.

0.010" = 0.25 mm.

0.015" = 0.396 mm.

0.020" = 0.51 mm.

0.025" = 0.635 mm.

0.030" = 0.76 mm.

0.032" = 0.81 mm.

0.045" = 1.04 mm.

0.049" = 1.24 mm.

0.150" = 3.8 mm.

PART 4

MODEL RB340 REGULATOR — SINGLE CONTACT 3 BOBBIN TYPE CURRENT VOLTAGE CONTROL REGULATOR TESTS WITH UNIT IN POSITION

Instruments required: Moving Coil Ammeter 0 – 40 amperes

Moving Coil Voltmeter 0 – 20 volts

Special Tool Part No. 543 817 42

Except for adjustment of the cut-out relay drop-off voltage, which is effected by bending the fixed contact bracket, electrical settings are made by turning toothed adjustment cams carried on the front limb of each magnet frame. A special tool is available for this purpose. Back air gaps are fixed and non-adjustable and the only mechanical settings that may be required comprise simple adjustments to the armature-to-bobbin core air gaps.

The Current regulator is adjusted, before leaving the factory, to suit the rated output of the generator which it is to control. The nominal setting is rubber-stamped either on the underside of the 'B-B' terminal plate or on the cover. In addition a list of Lucas generators together with their rated output is given in the appropriate section of this booklet. The model of the generator, which is stamped on the yoke of the machine can be noted before commencing the tests.

Temperature Correction Factor

Corrections to be made to the open-circuit voltage limits when checking or adjusting settings at temperatures other than 20°C (68°F) are as follows:—

For every 10°C (18°F) *above* 20°C *subtract* 0.2 volt from the 12-volt limits

Conversely, the same corrections must be *added* for every 10°C *below* 20°C

For generator tests, repeat Tests 1 – 4, of Part 1, then proceed to Test 5, on page 18.

from
per,
the

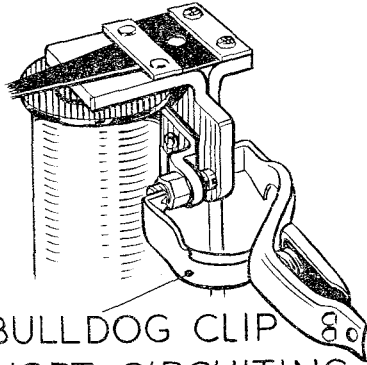
AMMETER CONNECTION	READING	ACTION																																							
<p>TEST 5 : Current Regulator. Reconnect leads to D and F on generator. Remove control box cover. Short out voltage regulator contacts with a bulldog clip. Using a suitable 'jumper lead' connect the leads to the load side of 0 - 40 ammeter. Connect other lead of ammeter to one of control box terminal blades B-B.</p> <p>Note: It is important to ensure that terminal B-B carries only this one connection. All other load connections (including the ignition coil feed) must be made to the battery side of the ammeter.</p> <p>Switch on lights to ensure generator develops its rated output.</p>	<p>A. Ammeter pointer should be steady and indicate a current equal to maximum rated output of generator:</p> <table border="0"> <tr> <td>C40/1</td> <td>12V:20 amps. ± 1 amp.</td> <td>(with $4\frac{1}{2}$" dia. fan)</td> </tr> <tr> <td>C40/1</td> <td>12V:22 amps. ± 1 amp.</td> <td>(with 5" dia. fan)</td> </tr> <tr> <td>C45PV-5</td> <td>12V:22 amps. ± 1 amp.</td> <td></td> </tr> <tr> <td>C45PV-6</td> <td>12V:25 amps. ± 1 amp.</td> <td></td> </tr> <tr> <td>C45PVS-6</td> <td>12V:25 amps. ± 1 amp.</td> <td></td> </tr> <tr> <td>C39PV-2</td> <td>12V:19 amps. ± 1 amp.</td> <td></td> </tr> <tr> <td>C47</td> <td>12V:30 amps. $\pm 1\frac{1}{2}$ amps.</td> <td></td> </tr> <tr> <td>C48</td> <td>12V:35 amps. $\pm 1\frac{1}{2}$ amps.</td> <td></td> </tr> <tr> <td>C40AL</td> <td>12V:11 amps. ± 1 amp.</td> <td></td> </tr> <tr> <td>C40L</td> <td>12V:25 amps. ± 1 amp.</td> <td></td> </tr> <tr> <td>C40LQ</td> <td>12V:25 amps. ± 1 amp.</td> <td></td> </tr> <tr> <td>C42</td> <td>12V:30 amps. $\pm 1\frac{1}{2}$ amps.</td> <td></td> </tr> <tr> <td>(Easidrive)</td> <td>12V:35 amps. $\pm 1\frac{1}{2}$ amps.</td> <td></td> </tr> </table>	C40/1	12V:20 amps. ± 1 amp.	(with $4\frac{1}{2}$ " dia. fan)	C40/1	12V:22 amps. ± 1 amp.	(with 5" dia. fan)	C45PV-5	12V:22 amps. ± 1 amp.		C45PV-6	12V:25 amps. ± 1 amp.		C45PVS-6	12V:25 amps. ± 1 amp.		C39PV-2	12V:19 amps. ± 1 amp.		C47	12V:30 amps. $\pm 1\frac{1}{2}$ amps.		C48	12V:35 amps. $\pm 1\frac{1}{2}$ amps.		C40AL	12V:11 amps. ± 1 amp.		C40L	12V:25 amps. ± 1 amp.		C40LQ	12V:25 amps. ± 1 amp.		C42	12V:30 amps. $\pm 1\frac{1}{2}$ amps.		(Easidrive)	12V:35 amps. $\pm 1\frac{1}{2}$ amps.		<p>Current regulator is in order, proceed to Test 6.</p>  <p>BULLDOG CLIP SHORT CIRCUITING VR CONTACTS.</p>
C40/1	12V:20 amps. ± 1 amp.	(with $4\frac{1}{2}$ " dia. fan)																																							
C40/1	12V:22 amps. ± 1 amp.	(with 5" dia. fan)																																							
C45PV-5	12V:22 amps. ± 1 amp.																																								
C45PV-6	12V:25 amps. ± 1 amp.																																								
C45PVS-6	12V:25 amps. ± 1 amp.																																								
C39PV-2	12V:19 amps. ± 1 amp.																																								
C47	12V:30 amps. $\pm 1\frac{1}{2}$ amps.																																								
C48	12V:35 amps. $\pm 1\frac{1}{2}$ amps.																																								
C40AL	12V:11 amps. ± 1 amp.																																								
C40L	12V:25 amps. ± 1 amp.																																								
C40LQ	12V:25 amps. ± 1 amp.																																								
C42	12V:30 amps. $\pm 1\frac{1}{2}$ amps.																																								
(Easidrive)	12V:35 amps. $\pm 1\frac{1}{2}$ amps.																																								
<p>Start engine and run generator at 4,500 rev/min (4,000 rev/min for C48).</p>	<p>B. Ammeter pointer remains steady but current reading outside limits.</p>	<p>Turn the current adjustment cam until correct setting is obtained — turning the tool clockwise to raise the setting or anti-clockwise to lower it.</p>																																							

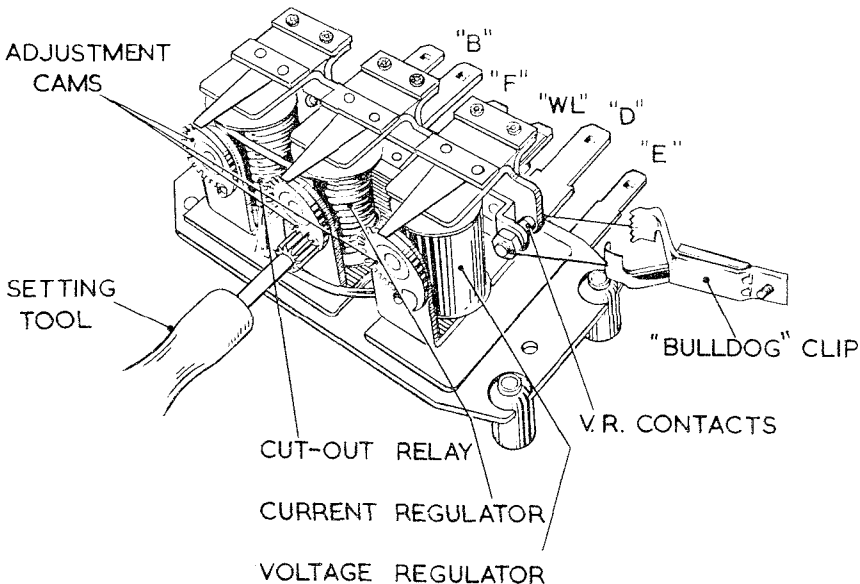
AMMETER CONNECTION	READING	ACTION
<p>TEST 5 (continued).</p> <p>(CURRENT REGULATOR ADJUSTMENT)</p>  <p>ADJUSTMENT CAMS</p> <p>SETTING TOOL</p> <p>CUT-OUT RELAY</p> <p>CURRENT REGULATOR</p> <p>VOLTAGE REGULATOR</p> <p>"B"</p> <p>"F"</p> <p>"WL"</p> <p>"D"</p> <p>"E"</p> <p>"BULLDOG" CLIP</p> <p>V.R. CONTACTS</p>	<p>C. An unsteady reading, i.e. pointer is fluctuating more than ± 1 amp.</p>	<p>Check for dirty contacts, or foreign matter in air gaps.</p> <p>If in order, check air gap setting between armature and bobbin core as follows :—</p> <p>Turn the adjustment cam to the point giving minimum lift to the armature tensioning spring, by turning the tool to the fullest extent anti-clockwise.</p> <p>Slacken the adjustable contact locking nut and screw back the adjustable contact.</p> <p>Insert a flat steel feeler gauge of 0.045" (1.04 mm.) thickness between the armature and the copper separation on the core face. The gauge should be inserted as far back as the two rivet heads on the underside of the armature.</p> <p>Retaining the gauge in position and pressing squarely down on the armature, screw in the adjustable contact until it just touches the armature contact.</p> <p>Re-tighten the locking nut and withdraw the gauge.</p> <p>Carry out the electrical setting procedure.</p> <p>If still not within limits fit a replacement unit.</p>

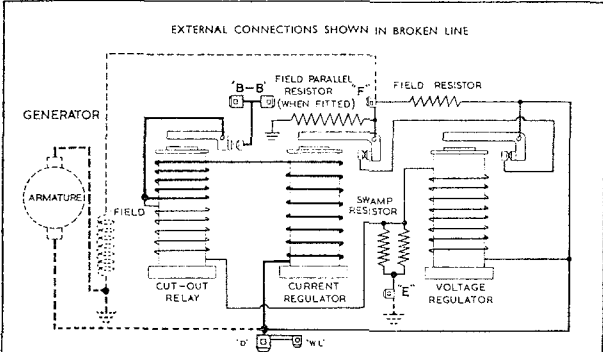
VOLTMETER CONNECTION	READING	ACTION
TEST 6 (continued).	B. Voltage reading remains constant but outside appropriate limits.	Adjust regulator by rotating the adjustment cam. Turn the tool clockwise to raise the setting or anti-clockwise to lower it.
	C. Rising volts with rising engine, speed up to 3,000 rev/min and beyond.	Check D and F leads for short-circuit, if O.K. suspect broken shunt winding in regulator bobbin. Shunt windings on both voltage regulator and cut-out bobbins are to common earth. Hold a screwdriver near top of voltage and cut-out bobbins and test for magnetic pull. If no pull check for open circuited ground lead or shunt winding. If defective fit replacement regulator.
 <p>EXTERNAL CONNECTIONS SHOWN IN BROKEN LINE</p> <p>GENERATOR</p> <p>ARMATURE</p> <p>FIELD</p> <p>CUT-OUT RELAY</p> <p>CURRENT REGULATOR</p> <p>FIELD PARALLEL RESISTOR (WHEN FITTED)</p> <p>FIELD RESISTOR</p> <p>SWAMP RESISTOR</p> <p>VOLTAGE REGULATOR</p> <p>NOTE: UNTIL EARLY IN 1962, THE V.R. & C.R. MAGNET FRAMES WERE LINKED BY A CONNECTOR THROUGH WHICH (IN THE CONTACTS CLOSED POSITION) THE FIELD CURRENT PASSED, VIA THE C.O. & C.R. SERIES WINDINGS, TO TERMINAL 'D'.</p>	D. Voltmeter reading fluctuates, i.e., pointer fluctuating more than 0.3-volt.	Check for dirty contacts, or foreign matter in gaps. If in order check air gap between armature and bobbin core face, as follows: Turn the adjustment cam to the point giving minimum lift to the armature tensioning spring, by turning the tool to the fullest extent anti-clockwise. Slacken the adjustable contact locking nut and screw back the adjustable contact. Insert a flat steel feeler gauge of 0.045" (1.04 mm.) thickness between the armature and the copper separation on the core face. The gauge should be inserted as far back as the two rivet heads on the underside of the armature. (continued)

VOLTMETER CONNECTION	READING	ACTION
TEST 6 (continued)	D. (continued)	Retaining the gauge in position and pressing squarely down on the armature, screw in the adjustable contact until it just touches the armature contact. Retighten the locking nut and withdraw the gauge. Carry out the electrical setting procedure. <i>If still not within limits fit a replacement unit.</i>
TEST 7. With engine stationary. Reconnect leads to B-B terminal on control box. Connect voltmeter between B-B terminal and ground.	Battery voltage.	Circuit from battery to regulator is in order. Proceed to Test 8.
TEST 8. Leave voltmeter connected as for Test 7. Start engine, and slowly increase speed, closely watching voltmeter dial.	A. As cut-out closes, reading rises to 0.5 to 1.0 volts above battery voltage, and continues to rise as engine speed is steadily increased, until regulator setting voltage, as given in Test 6, is reached.	Cut-out is in order. Proceed to Test 9.
	B. No voltage or very low voltage is registered when cut-out contacts close.	Check for dirty or burned contacts. Check for contact alignment. Check that they meet correctly when armature is pressed down, the moving contact blade should have a deflection of 0.010" – 0.020". Armature back stop to core air gap should be between 0.035" – 0.045".

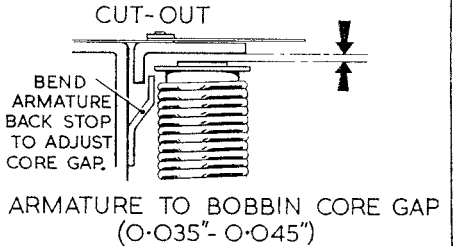
VOLTMETER CONNECTION	READING	ACTION
<p>TEST 9 : Cut-in Voltage. Connect voltmeter between D on control box and ground. Switch on headlamps. Start engine and slowly increase its speed. Observe the voltmeter pointer.</p>  <p>ARMATURE TO BOBBIN CORE GAP (0.035" - 0.045")</p>	<p>A. Voltage reading rises steadily and then drops slightly at the instant the contacts close. The cut-in voltage is that which is indicated immediately before the pointer drops back. It should occur between the following limits:— 12.6 – 13.4 volts.</p>	<p>Cut-out is in order. Proceed to Final Check, Test 10.</p>
	<p>B. Cut-out contacts close outside limits.</p>	<p>Adjust cut-out by rotating the adjustment cam, turn the tool clockwise to raise the setting or anti-clockwise to lower it. Again check cut-in voltage. Repeat procedure until correct setting obtained.</p>
	<p>C. Cut-out contacts will not close.</p>	<p>Fit a replacement unit.</p>

VOLTMETER CONNECTION	READING	ACTION
<p>TEST 10 : Drop off voltage. Withdraw leads control box B-B terminals. Connect voltmeter between B-B terminals and ground. Start engine and run up to 3,000 rev/min. Slowly decelerate and observe voltmeter pointer.</p>	<p>A. Opening of contacts, indicated by the voltmeter pointer dropping to zero, this should occur between the following limits : 9.3 – 11.2 volts</p>	<p>Control box in order.</p>
	<p>B. Drop-off occurs outside limits.</p>	<p>Adjust Drop-off volts as follows :— Stop engine, and adjust the drop-off voltage by carefully bending the fixed contact bracket. Reducing the contact gap will raise the drop-off voltage; increasing the gap will lower the drop-off voltage. Re-test and, if necessary, readjust until the correct drop-off setting is obtained. Note: When drop-off voltage is correct the moving contact blade should have a 'follow through' or blade deflection of 0.010" – 0.020". The armature back stop, when free, should give a core gap of 0.035" – 0.045", adjust by bending stop with a suitable tool.</p>

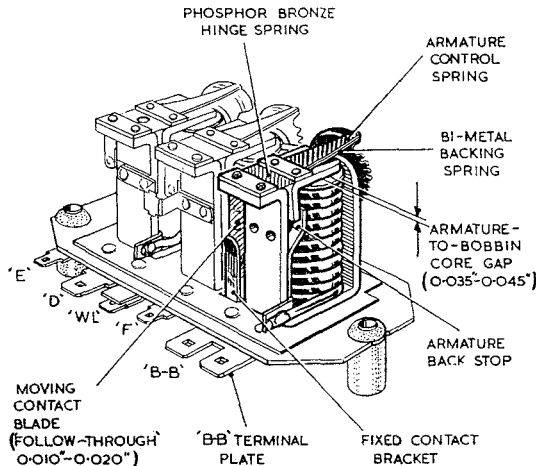

RB340 DESIGN DATA (12-volt units)

RESISTOR VALUES

(i) Contacts Resistor :	Resistance in Ohms	Identification Colour
As fitted to units controlling 12-volt generators having $4\frac{1}{2}$ ohm field windings :	37 - 43	Yellow
As fitted to units controlling 12-volt generators having 6 ohm field windings :	55 - 65	Red

(ii) Swamp Resistor :	Resistance in Ohms	RESISTANCE OF SHUNT WINDINGS at 20°C (68°F) Voltage
(12-volt Units) Measured on unit between centre tag and base :	13.25 - 14.25	Regulator: 10.8-12.0 ohms Cut-out : 8.8 - 9.6 ohms

Replacement resistor measured between end tags before fitting to unit :

53 - 57	ADJUSTMENT CAMS
	Torque to turn cams : 2 - 4 lb. in. (0.023 - 0.046 kg m.)

(iii) Field Parallel Resistance :	37 - 43
As fitted to units controlling model C48 generator :	AIR GAPS

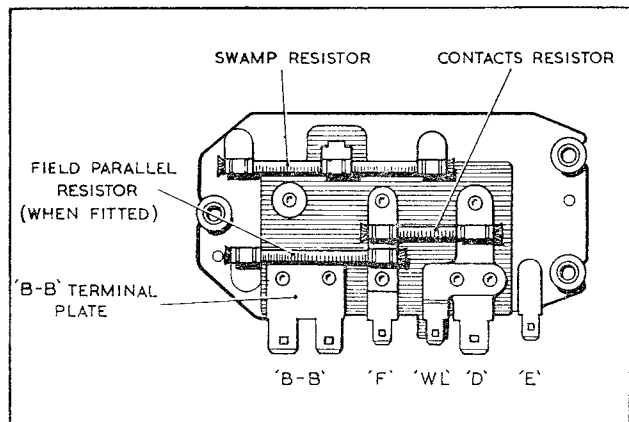

	Length
Armature back gaps (non-adjustable) :	0.030" - 0.035" (0.76 - 0.9 mm.)
Armature-to-bobbin core, VR and CR :	0.045" - 0.049" (1.04 - 1.24 mm.)
Armature-to-bobbin core, Cut-out relay :	0.035" - 0.045" (0.9 - 1.04 mm.)
'Follow-through' or blade deflection of cut-out relay moving contact :	0.010" - 0.020" (0.25 - 0.51 mm.)

CONTACT REPLACEMENT SETS

Contact replacement sets are supplied solely for use overseas, where special service problems are encountered. The fitting of these sets involves the replacement of existing rivets with screws. The Part Numbers of the sets are 543 820 77—8 and 9 for the Cut-out Relay, Voltage and Current Regulators, respectively. Each set comprises an Armature Assembly, Clamp Plate, Fixed Contact Screw and Nut (or, for cut-out relays, a 'B-B' Terminal Plate Assembly), and two 5 BA screws with associated spring washers and lock nuts (two extra screws, spring washers and lock nuts being provided for the cut-out relay to secure the above terminal plate assembly).

IDENTIFICATION OF ARMATURE ASSEMBLIES

- (i) *Cut-out relay armature* : Moving contact carried on phosphor bronze blade. Phosphor bronze hinge spring unpierced. Blued steel control spring backed with bi-metal spring (high expansion side lowermost).
- (ii) *Voltage regulator armature* : Bi-metal hinge spring pierced with central 0.150" (3.8 mm.) hole. (High expansion side of bi-metal uppermost).
- (iii) *Current regulator armature* : Blued steel hinge spring, unpierced.

FITTING ARMATURE ASSEMBLIES

- (i) Carefully remove existing rivets, using a file, centre-punch, twist drill ($\frac{3}{32}$ " diameter; 2.38 mm.), and a parallel-sided punch ($\frac{5}{64}$ " diameter; 1.98 mm.), in that order.

- (ii) Discard original armature, clamp plate, and fixed contact screw and nut, or, when replacing a cut-out relay armature, the 'B-B' terminal plate.
- (iii) Loosely assemble replacement parts to magnet frame, noting that the armature hinge spring has open-ended slotted fixing holes to facilitate fitting under the clamp plate. Do not insert the fixed contact screw of the VR or CR more than $1\frac{1}{2}$ to 2 turns at this stage.
- (iv) When applicable, fit and tighten replacement 'B-B' terminal plate, inserting the securing screws from the upper side of the control box base plate.
- (v) Insert a 0.032" (0.81 mm.) feeler gauge approximately half-way up the back air gap.
- (vi) Insert a 0.045" (1.04 mm.) feeler gauge in the armature-to-bobbin core gap as far back as the two tension spring rivets.
- (vii) Press the armature squarely down towards the bobbin core and back towards the magnet frame, firmly trapping both gauges.
- (viii) Tighten the armature assembly securing screws.
- (ix) Withdraw gauges and carry out mechanical and electrical adjustments.

ADJUSTMENT SEQUENCE

After fitting a replacement contact set (or sets), the regulator or cut-out relay concerned must be adjusted both mechanically and electrically. The order of electrical settings (when all three armatures have been replaced) being, first, the voltage regulator, secondly the cut-out relay and, thirdly, the current regulator.

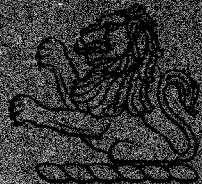

LUCAS