

WIRING DIAGRAM - TR7 USA - AIR CONDITIONING

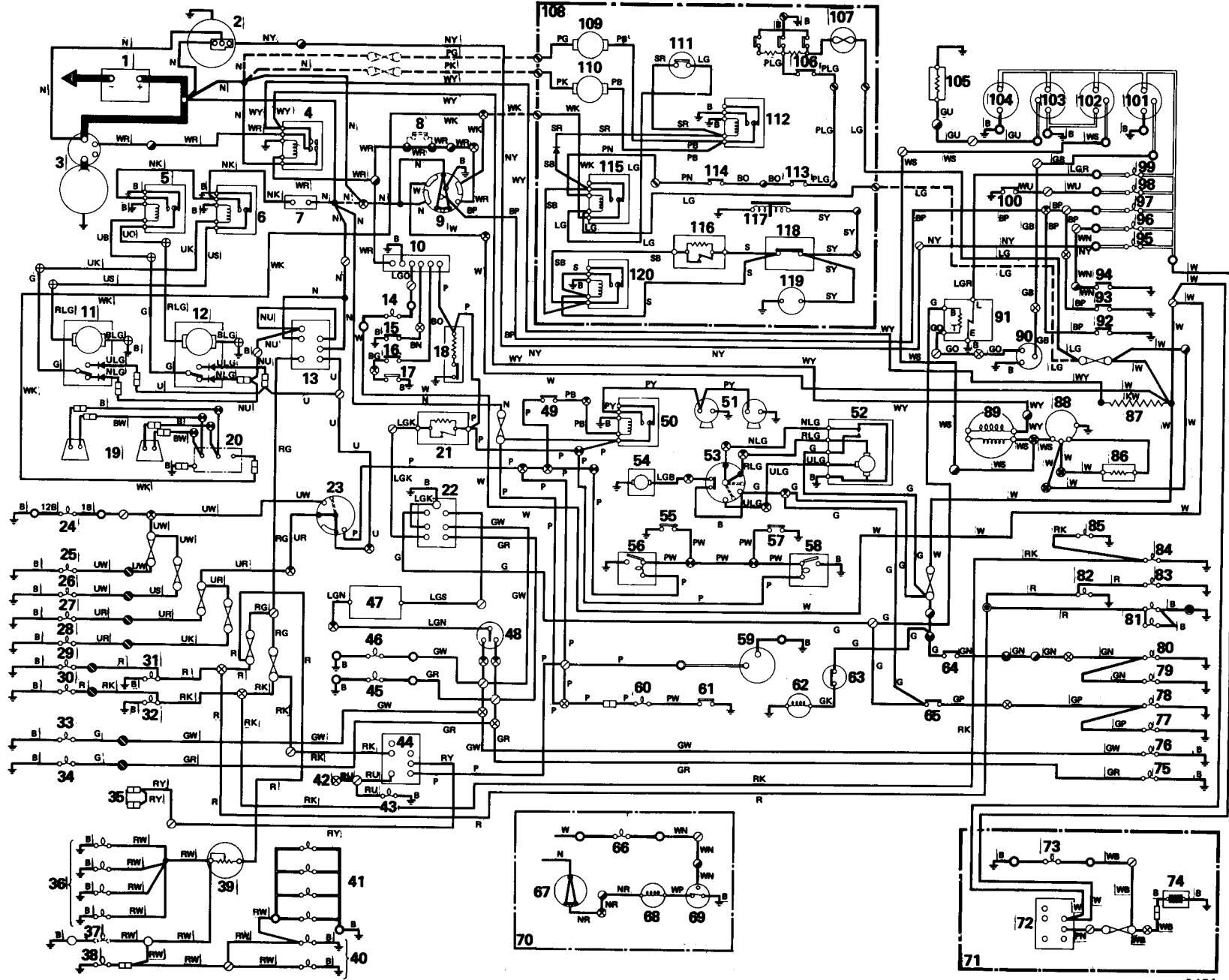

WIRING DIAGRAM KEY
TR7 – TR7 USA – AIR CONDITIONING

1	Battery	31	R.H. side marker	61	Boot lamp switch	91	Low fuel relay unit
2	Alternator	32	L.H. side marker	62	F.A.S.D.	92	Brake pressure differential switch
3	Starter motor	33	R.H. side indicator	63	Engine thermostat	93	Hand brake switch
4	Starter motor relay	34	L.H. side indicator	64	Reverse light switch	94	Oil pressure switch
5	R.H. headlamp relay	35	Front fog lamps junction	65	Stop light switch	95	Ignition warning light
6	L.H. headlamp relay	36	Heater control illumination	66	Oil warning light	96	Oil warning light
7	Headlamp motor circuit breaker	37	Borg-Warner illumination	67	Ignition switch	97	Brake warning light
8	Start inhibit switch (Automatic)	38	Cigar lighter illumination	68	Anti-run-on valve	98	Choke warning light
9	Ignition switch	39	Panel rheostats	69	Oil pressure switch	99	Low fuel warning light
10	Buzzer timer unit	40	Switch panel illumination	70	Anti-run-on valve – California market only	100	Choke warning light switch
11	L.H. headlamp motor	41	Panel illumination	71	Heated rear screen – TR7 coupé	101	Fuel gauge
12	R.H. headlamp motor	42	Rear fog lamps illumination	72	Heated rear screen switch	102	Tachometer
13	Master light switch	43	Rear fog lamps warning light	73	Heated rear screen warning light	103	Temperature gauge
14	Seat belt warning light	44	Fog lamps switch	74	Heated rear screen	104	Battery condition indicator
15	Buckle switch	45	L.H. indicator warning light	75	L.H. side indicator	105	Temperature transmitter
16	Door switch	46	R.H. indicator warning light	76	R.H. side indicator	106	Thermostat
17	Audible warning	47	Flasher unit	77	L.H. stop light	107	Heater/air conditioning blower unit
18	Cigar lighter	48	Direction indicator switch	78	R.H. stop light	108	Air conditioning circuit
19	Loudspeakers	49	Horn-push	79	L.H. reverse light	109	R.H. condenser fan
20	Radio	50	Horn relay	80	R.H. reverse light	110	L.H. condenser fan
21	Hazard unit	51	Horns	81	Number-plate lights	111	Radiator thermostat
22	Hazard switch	52	Windscreen wiper motor	82	R.H. side marker	112	Fan relay
23	Main/dip/flash switch	53	Windscreen wipe/wash switch	83	R.H. tail lights	113	Full throttle cut-off switch
24	Main beam warning light	54	Windscreen washer motor	84	L.H. tail lights	114	Air conditioning cut-out switch
25	R.H. main beam	55	Door switch	85	L.H. side marker	115	Air conditioning relay
26	L.H. main beam	56	Courtesy light	86	Drive resistor	116	Delay unit
27	R.H. dip beam	57	Door switch	87	Eureka wire (1.3 to 1.5 ohms)	117	Throttle jack
28	L.H. dip beam	58	Courtesy light	88	Distributor	118	Ranco valve high pressure cut-off
29	R.H. sidelight	59	Clock	89	6 volt	119	Clutch
30	L.H. sidelight	60	Boot lamp	90	Tank unit	120	Clutch relay

COLOUR CODE

N	Brown	LG	Light Green
U	Blue	W	White
R	Red	Y	Yellow
P	Purple	S	Slate
G	Green	B	Black
K	Pink	O	Orange